

How Do Space Energy Devices Work?

An explanation by means of Einstein-Cartan-Evans Theory.

Dr. Horst Eckardt

Alpha Institute for Advanced Study (www.aias.us)

Abstract

Newly developed energy devices seem to acquire energy “from nothing“. Their working mechanism is not explainable through standard physics. In this paper we show how Einstein-Cartan-Evans theory is able to explain the mechanism. Resonances of ambient spacetime are created to transfer energy from spacetime itself to the devices, so that energy is conserved. The concept is applied to two main types of devices: electrical solid-state devices and magnetic self-rotating motors. The description is kept on a level requiring only knowledge in vector analysis and basic differential equations.

1. Introduction

Today many attempts are being made to solve the world-wide energy crisis. Oil and gas will be available to provide energy only for a limited number of years. The environmental problems caused by these energy sources are enormous, in particular global climate warming, which is already observable today. Therefore governments and environmental research groups are searching for substitutes of fossil fuels. A wide range is being considered; from biologically generated fuel to solar and wind energy. It is a common feature of all these replacement substances and methods that the energy supplied by such, either in the form of heat or electric power, are not produced in sufficient quantities from them. For example, it would be necessary to cover huge surfaces of land with solar cells or wind turbines, which is not entirely feasible in some industrialized countries. A basic solution to this problem needs to be found, but this is not in sight, at least from the official research in energy technologies.

When facing the energy crisis all possibilities for finding new energy sources need to be evaluated, even if the success is not directly obvious. This is done, for example, with nuclear fusion reactors, but many other fields do not receive enough attention. In this latter group we can find the so-called vacuum energy, as well as a number of inventions which are considered as non-existent or fakes in the eyes of the official science community. This attitude is in disregard of the fact that the physical vacuum is known to be non-empty and to have a high energy density. This possible source of renewable energy has been ignored by the scientific establishment due to the fact that the basic physical principles involved in it are not fully understood.

Meanwhile, however, a growing number of inventions have emerged, the mechanisms of which are not explainable through standard physics theory. Some of them are being developed to production scale, so that such alternative energy devices might be commercially available in the near future. The big question which arises when dealing with these devices refers to how are they seemingly able to create usable energy apparently “from nothing”. Since conventional science cannot explain the mechanisms used by these devices to operate, inventors have been relying on hypothesis which are at best physics-based ad-hoc assumptions or in other cases some kind of philosophical principles which lie outside acceptable scientific methods.

The dilemma is resolved by means of the Einstein-Cartan-Evans (ECE) theory. This is the only known scientific theory which is able to give an explanation of these devices on the basis of physics, while making use of a mathematically sound method. ECE theory is an extension of Einstein’s general relativity theory through the ideas developed by the French mathematician Élie Cartan around 1922. Dr. Myron W. Evans brought this into a final form in 2003. The unified field theory which resulted could be considered as a new basis for many areas of physics. Existing fields like quantum physics and Newtonian mechanics emerge as special limits of the new theory. In addition, surprising new mechanisms have evolved from its principles, unknown until now, in particular mechanisms for extracting energy from spacetime. The spacetime takes over the role which some avant-garde physicists ascribed to vacuum in the past.

According to ECE theory, energy can be extracted from spacetime without sacrificing energy conservation. The mechanism is based on a resonant coupling of the device with the spacetime itself. The general characteristics of this effect are described in this paper, where it is applied to two different types of devices: electrical solid-state structures and magnetic motors. Details are found in the scientific papers [1] - [6]. In this article we try to describe the essential points and present them on a level which might be comprehensible to engineers.

2. Resonant Coulomb Law

Experiments with electric devices [8] have shown that extraction of energy from spacetime is possible. A small input power can be enhanced up by a factor of 100,000 or more. This effect of energy extracted from spacetime does only appear in configurations where a certain resonance condition has been met. So for an understanding of its operation it is necessary to find possible resonances in the underlying physics. The structure of solids is mainly determined by the Coulomb law, which describes the interaction between atomic nuclei and electrons, as well as the electrons among each other. The electric field \vec{E} of a charge density ρ is determined by the Coulomb law:

$$(1) \quad \nabla \cdot \vec{E} = \frac{\rho}{\epsilon_0}$$

where the field \vec{E} is the gradient of an electric scalar potential Φ :

$$(2) \quad \vec{E} = -\nabla\Phi.$$

These are elementary equations of classical electrodynamics of Maxwell and Heaviside and there is no resonance involved in them.

Now ECE theory comes into play. According to ECE theory, gravitation is described by the curvature of spacetime while electromagnetism is represented by the spinning of spacetime. The curvature of spacetime was introduced by Einstein in his theory of general relativity, in 1915. This means that space is curved in presence of masses (or more precisely, energy distributions). Therefore, Euclidian geometry cannot be used to describe a curved spacetime, so there was no other choice but to make use of Riemannian geometry. The incorporation of curvature requires a modification of differential calculus in Riemannian space: an additional term called the Christoffel symbol, or the Christoffel connection is required and added to the partial derivatives which occur, for example in Eqs. (1) and (2).

Electromagnetism is described by Cartan torsion, as suggested by Cartan in 1922. This requires a further change in differential calculus. Instead of the Christoffel connection, the so-called spin connection is to be used, in order to adequately describe the spinning of spacetime. This enables the laws of nature to become “generally covariant”, i.e. they keep their form in any coordinate system, in this case a curved as well as a spinning spacetime. This is not the case for classical electrodynamics, which obeys only special relativity, not general relativity.

The formalism can be simplified [3] to a vector of spin connection $\vec{\omega}$, which can be imagined

to be an axis of rotation in some simple cases. Since electromagnetism is spinning spacetime, we can apply now the Cartan torsion to Eqs. (1) and (2). The first equation suffers no changes and remains as is, while in the second equation the spin connection term is to be added to the partial derivatives (gradient operator):

$$(3) \quad \nabla \cdot \vec{E} = \frac{\rho}{\epsilon_0},$$

$$(4) \quad \vec{E} = -(\nabla + \vec{\omega})\Phi.$$

Inserting (4) into (3) gives

$$(5) \quad \Delta\Phi + \vec{\omega} \cdot \nabla\Phi + (\nabla \cdot \vec{\omega})\Phi = -\frac{\rho}{\epsilon_0}$$

where $\vec{\omega}$ is a function of the coordinates in general. This is a generalization of the classical Poisson equation which is obtained in the limit $\vec{\omega} = 0$:

$$(6) \quad \Delta\Phi = -\frac{\rho}{\epsilon_0}.$$

In Eq. (5) we have arrived at a differential equation of the Bernoulli type, which in one dimension can be expressed as:

$$(7) \quad \frac{\partial^2\Phi}{\partial x^2} + \alpha \frac{\partial\Phi}{\partial x} + \omega_0^2\Phi = f(x).$$

This is the well-known equation of a forced oscillation, with resonance frequency ω_0 and damping factor α . The term $f(x)$ on the right hand side is the “driving force”. The difference with Eq. (5) is that in this case the coefficients are constant.

Eq. (5) can be rewritten to spherical polar coordinates. We assume $\vec{\omega}$ and Φ to be spherically symmetric, i.e. we consider only the radial coordinate r . From the condition that Eq. (5) takes the form of Eq. (6) in the off-resonance case ($\vec{\omega} \rightarrow 0$) one obtains that the radial component of $\vec{\omega}$ has the form

$$(8) \quad \omega_r = -\frac{1}{r}$$

and (5) can be rewritten as

$$(9) \quad \frac{d^2\Phi}{dr^2} + \frac{1}{r} \frac{d\Phi}{dr} - \frac{1}{r^2}\Phi = -\frac{\rho}{\epsilon_0}.$$

Assuming an oscillatory form of the charge density

$$(10) \quad \rho = \rho_0 \cos(\kappa r)$$

with a spatial frequency (wavenumber) κ , Eq. (9) can be transformed into an equation of an undamped oscillator. Lastly, the non-constant coefficients are responsible for this behavior. In Fig. 1 the resonance curves are shown. The red curve describes an ordinary resonance according to Eq. (7), while the green curve shows the resonance behavior of Eq. (9) describing the resonant Coulomb law. It can be seen that more than one resonance frequency occurs, and the resonances are relatively sharp. These peaks are due to spin connection resonance which is not present in Maxwell-Heaviside theory.

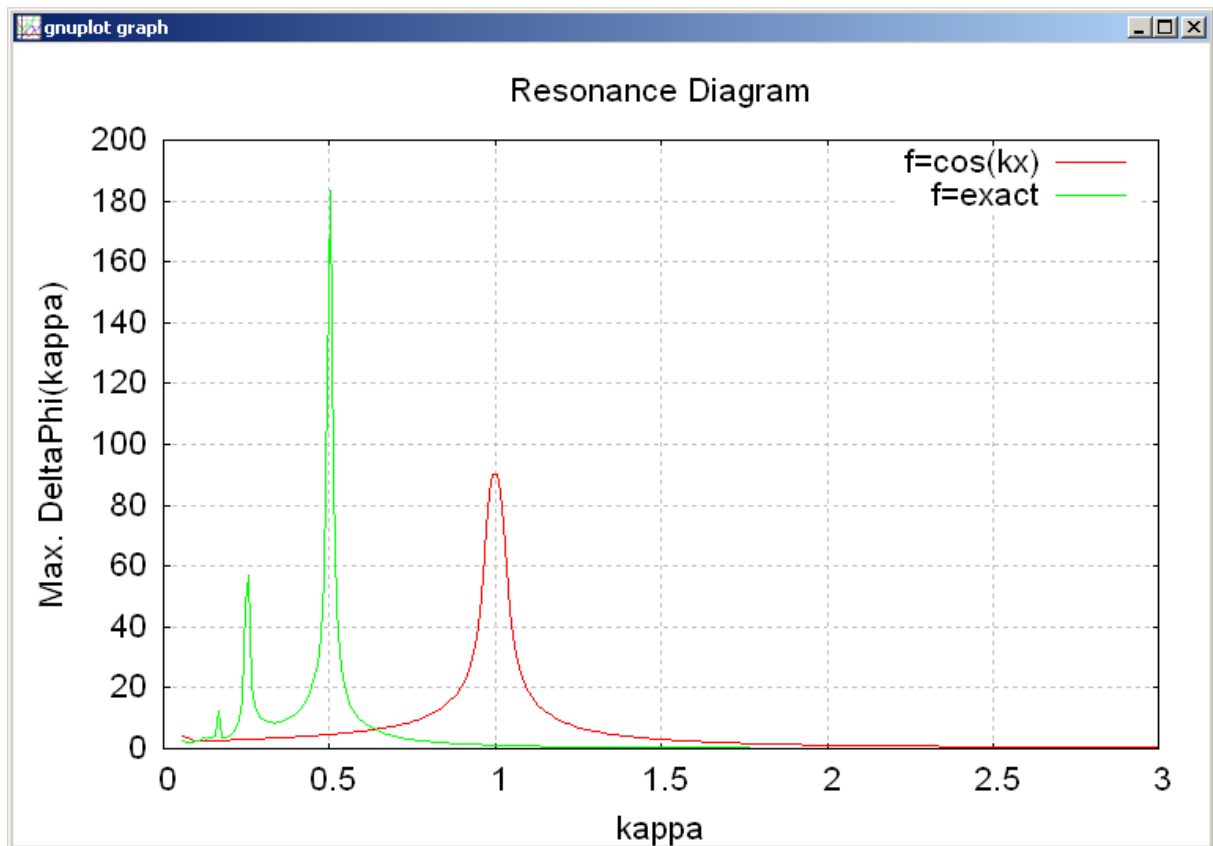

Fig. 1: Resonance diagram of resonant Coulomb law

In order to obtain energy from spacetime, the Coulomb potential of atoms, molecules or solids has to be brought to spin connection resonance. What happens to the electronic states of an atom is shown in Fig. 2. The energy eigenvalues of atomic hydrogen have been calculated in presence of a small oscillatory charge density serving as a driving force. The resulting ECE Coulomb potential has been added to the proton core potential of the H atom. It can be seen that all energy eigenvalues are shifted upwards at the main resonance. This means that the valence electron is pushed out of the atom, becoming a free electron. In a solid this means that the electron is lifted to the conduction band by resonance, and becomes part of a current source which can do external work.

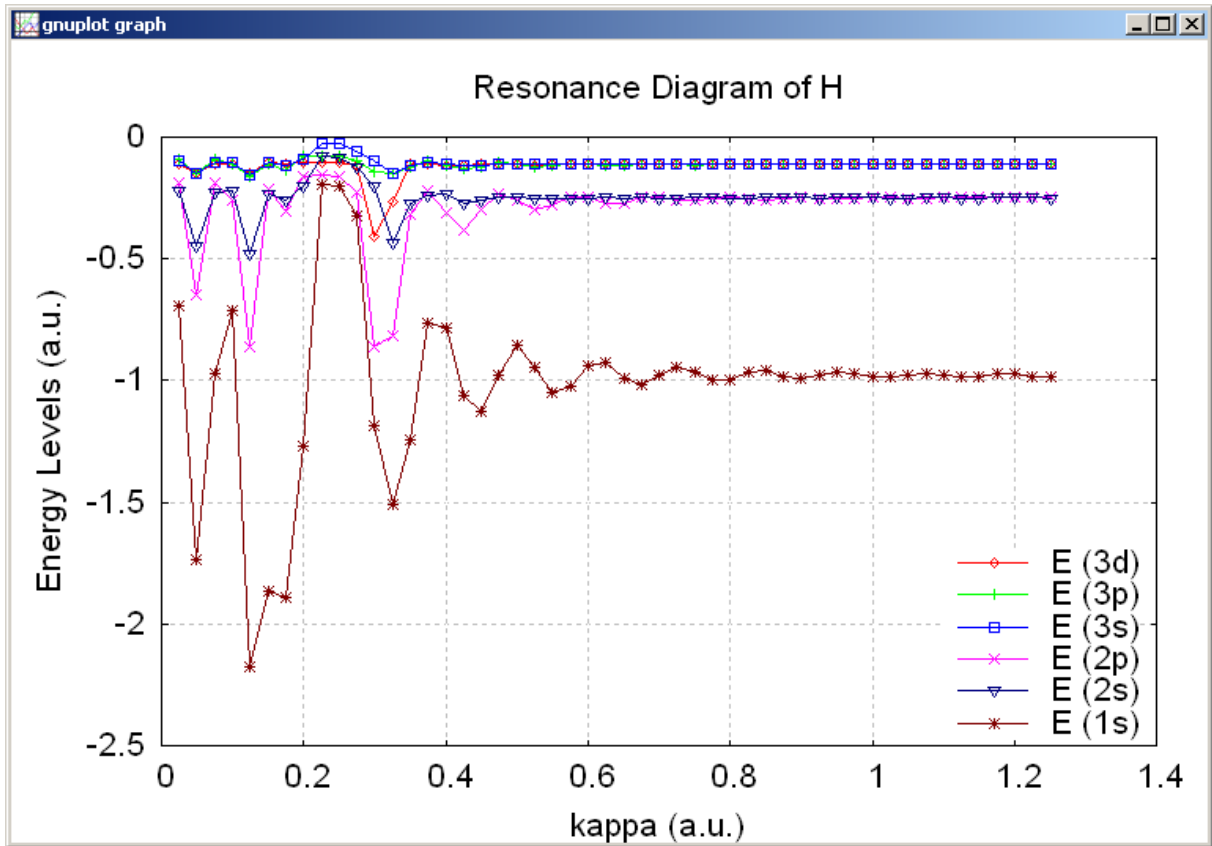

Fig. 2: Resonance diagram of atomic hydrogen

As we have seen spin connection resonance is obtained by applying a periodic charge density oscillation. The wavelength has to be comparable to the atomic distances. Such charge density oscillations can, for example, be evoked by spin waves in ferromagnetic materials. A detailed treatment of these effects requires application of developed methods for solid state physics, for example Density Functional Theory.

At the end of this section let us recall the excitation mechanism for Coulomb resonance (Fig. 3). The oscillating part in the mechanically driven oscillation is a mass, while in ECE Coulomb law it is the electrical potential. The restoring force of the spring corresponds to the spin connection, and the oscillating driving force is provided by the charge density. In mechanics a driven oscillation is an open system, the energy is transferred to the mass by the driving force. In the ECE Coulomb case the charge density remains unchanged while energy is transferred to the system (potential is increased). So this is also an open system as far as spacetime is not considered. Ignoring this fact leads to the erroneous assumption that the mechanism is that of a hypothetical perpetual motion device. But in the same way as a mechanical resonating mass is by no way a *perpetuum mobile*, neither it is in the case of the electrical system under consideration. Energy is transferred from spacetime, serving as an external reservoir in the same way as a mechanical driving force delivers the energy. So energy is perfectly conserved.

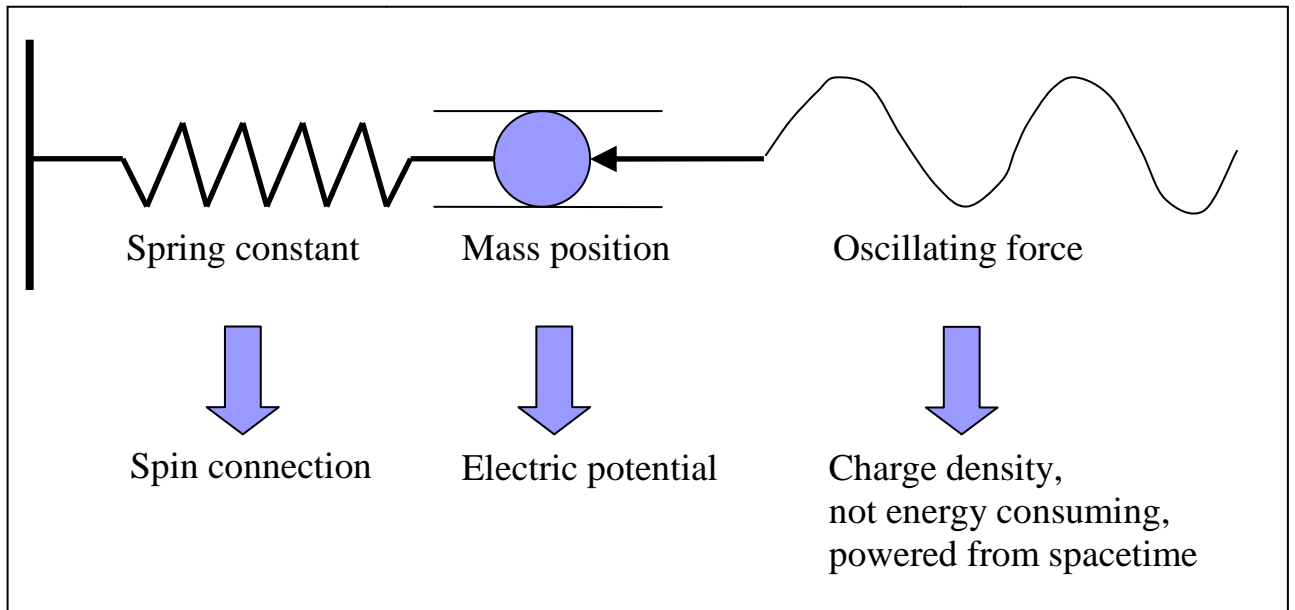

Fig. 3: Comparison mechanical – spin connection resonance

3. Magnetic Resonance Effects

Besides electrical spacetime devices, self-running magnetic motors have been constructed in a repeatable and reproducible way [10], see also Fig. 4, [11]). The functioning of these devices cannot be explained by Maxwell-Heaviside electrodynamics. Again we give an explanation by means of ECE theory.

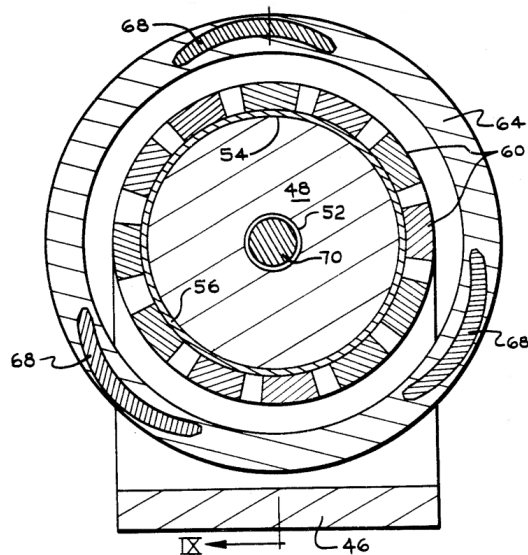

Fig. 4: Johnson magnetic motor [10]

As was described in the preceding section, the Cartan torsion of spacetime introduces the spin connection as an additional quantity occurring in the laws of nature, so that they take a generally covariant form. In particular this holds for the magnetic field. In Maxwell-

Heaviside theory, the magnetic field \vec{B} is connected with its generating vector potential \vec{A} by the relation

$$(11) \quad \vec{B} = \nabla \times \vec{A}.$$

In ECE theory this law has to be replaced in the simplest case by

$$(12) \quad \vec{B} = \nabla \times \vec{A} - \vec{\omega} \times \vec{A}$$

where $\vec{\omega}$ is the spin connection vector again. In the following we establish a difference between the magnetic field of the assembly and the magnetic field of the surrounding spacetime itself, which is denoted as \vec{B}_S . The torque \vec{T} , acting on the magnetic dipole-moment \vec{m} of the assembly due to the external magnetic field \vec{B}_S is

$$(13) \quad \vec{T} = \vec{m} \times \vec{B}_S.$$

Under normal conditions there is no resulting torque because of $\vec{B}_S = 0$. Spacetime is force-free and does not bear a magnetic field. So there is no rotation of stationary magnets. The situation becomes different if it were possible to create a magnetic field from spacetime. In order to understand how this can be achieved we have first to look closer at the fields of the surrounding spacetime. In the case of $\vec{B}_S = 0$ it follows from Eq. (12) that

$$(14) \quad \nabla \times \vec{A} = \vec{\omega} \times \vec{A},$$

where \vec{A} is the vector magnetic potential of the spacetime itself. In contrast to Maxwell-Heaviside theory, this is no gaugable quantity but is uniquely defined and has a physical meaning. In case of \vec{A} consisting of plane waves, $\vec{\omega}$ takes a special form and Eq. (14) can be expressed as

$$(15) \quad \nabla \times \vec{A} = -\kappa_B \vec{A}$$

with a wave number κ_B (see [6] for details). This equation is known as the Beltrami equation in the literature [7]. It describes a flow with longitudinal vortices (Fig. 5), where streamlines have a helical form. The closer a streamline is to the central axis, the more stretched it is, and the faster is the flow velocity. In contrast to flows which are described by the Navier Stokes equation (as is the case for airplane wings) there is no force acting on the elementary flow volumes. In the case of ECE potential this means that there is no force field present, in accordance with our prior assumption.

going to infinity. Because of violating the Beltrami condition, \bar{A} creates a force field according to Eq.(11), which via Eq.(13) creates a torque being big enough to spin the magnetic assembly and to maintain the rotation. This is the mechanism for how spacetime is able to do work via a resonance mechanism.

In Fig. 6 this is depicted schematically. Fig. 6a shows a stator with Beltrami (force-free) flow of the spacetime vector potential. The additional rotor magnets in Fig. 6b create vortices of spacetime which are enhanced by spacetime resonance and evoke a force field according to Eq. (11).

In total we have shown qualitatively how energy can be obtained from spacetime via magnetic assemblies. This could be the basis for development of an engineering model for such devices.

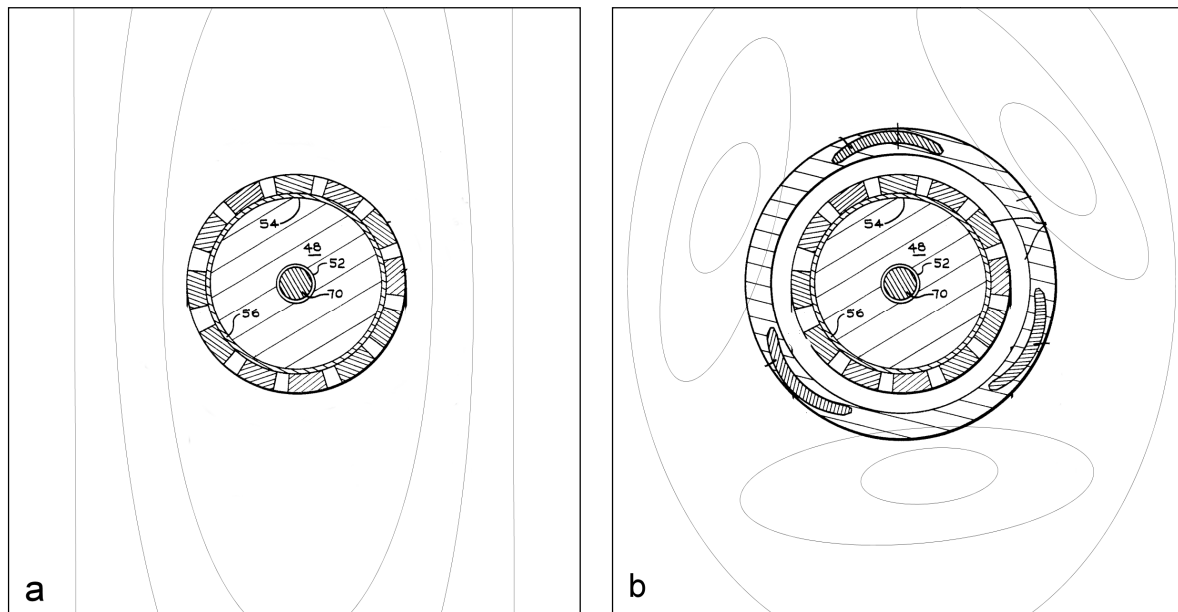

Fig. 6: Schematic representation of spacetime vector potential for a magnetic assembly:
a: magnet stator without rotor magnets, Beltrami flow.
b: magnet stator including rotor magnets, flow with vortices (force field).

References

- [1] Introductory documents on ECE theory on www.aias.us.
- [2] M. W. Evans, “Generally Covariant Unified Field Theory” (Abramis, 2005), vol. 1-4
- [3] M. W. Evans and H. Eckardt, “Space-Time resonances in the Coulomb Law”, paper UFT 61 of the ECE series on www.aias.us.

- [4] M. W. Evans and H. Eckardt, “The resonant Coulomb Law of Einstein-Cartan-Evans Field Theory”, paper UFT 63 of the ECE series on www.aias.us.
- [5] M. W. Evans, “Spin Connection Resonance (SCR) in magneto-statics”, paper UFT 65 of the ECE series on www.aias.us.
- [6] M. W. Evans and H. Eckardt, “Spin connection resonance in magnetic motors”, paper UFT 74 of the ECE series on www.aias.us.
- [7] D. Reed, “Beltrami vector fields in electrodynamics – a reason for reexamining the structural foundations of classical field physics?”, Modern Nonlinear Optics, Part 3, Second Edition, Advances in Chemical Physics, Volume 119, edited by Myron W. Evans, John Wiley and Sons, 2001. www.et3m.net
- [8] <http://www.et3m.net>.
- [9] G. Kasyanov, “Phenomenon of electrical current rotation in nonlinear electric systems, Violation of the law of charge conservation in the system”, New Energy Technologies, 2(21), pp. 28-30, 2005
- [10] Johnson permanent magnet motor, US Patent 4151431, 1979.
- [11] <http://www.gammamanager.com>.